

## Logo & Promotion Towels

26

### Point Your Emotions

#### Terry Towels

promotion, company,  
club & logo towels, ...

#### Terry Products

bath robes, terry blankets, ...

### ChromoJET characteristics

ChromoJET is the only digital printing system  
for terry products and other pile fabrics.

ChromoJET is a well proven technology  
which has been adapted to print on  
terry products.

The jets are injecting the dye deep into  
the terry fabric, so any desired penetration  
can be achieved.

ChromoJET works with all dyestuff  
groups (pigment and reactive).

# ChromoJET - Terry Towel Printing

## ChromoJET specifications

<b>Printer type:</b>	Digital jet printer with high speed valves
<b>Fabric thickness:</b>	2 – 20 mm
<b>Fabric weight:</b>	200 – 600 g/sqm
<b>Processing:</b>	piece by piece
<b>Print width:</b>	2.15 m or 2.4 m
<b>Number of colours:</b>	8, 12 or 16
<b>Jets per colour:</b>	32*, 64, 128 or 256
<b>Resolution:</b>	50 dpi, 75 dpi and 100 dpi
<b>Print speed:</b>	30, 60 or 120 piece per hour (size 150 x 70 cm)
<b>Printpaste/Dyestuff:</b>	Commercially available pigments
<b>Viscosity:</b>	up to 100 cps
<b>Pre treatment:</b>	not needed

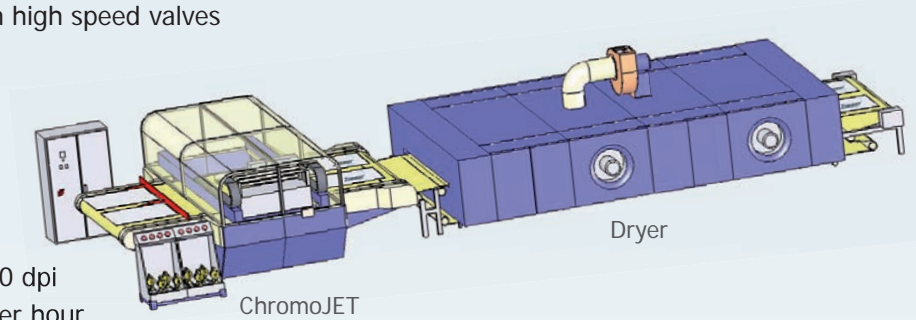

\*Only available for Mat Printer (Printer Combination)

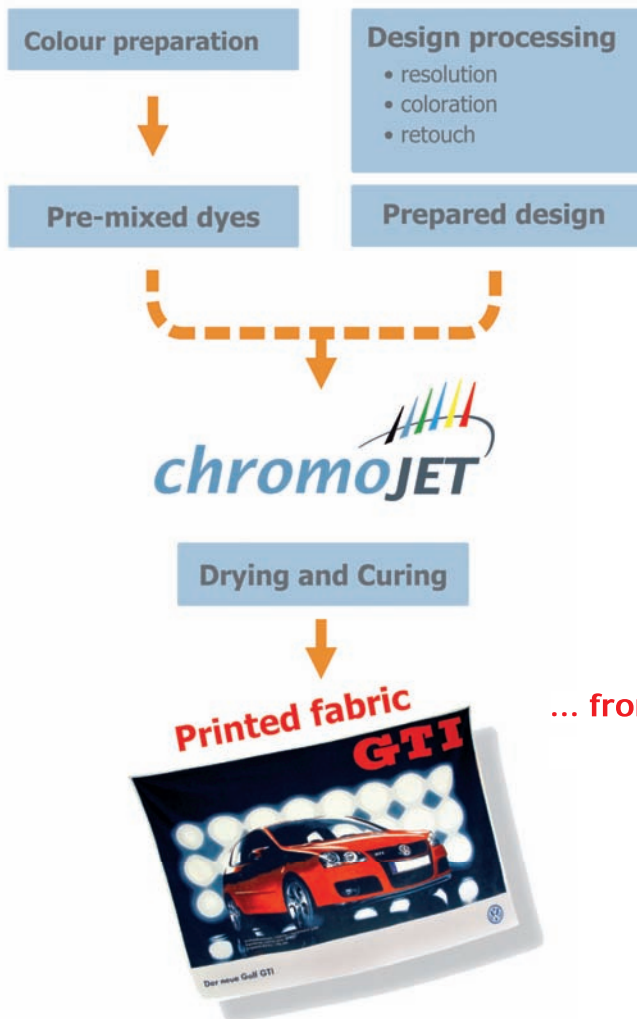

## Advantages of ChromoJET

- Maximum efficiency in short runs
- Lower cost for stock goods – just in time delivery
- No screens needed – unlimited repeat sizes
- Design change "on the fly"
- Low paste cost due to standard commercially available dyestuff
- High fastness level
- Brilliant shades
- Soft hand
- No fabric pre-treatment needed
- Adjustable penetration
- Spot colours with easy cleaning of paste supply system

... from the leading company for digital  
carpet & textile printing systems

**J. Zimmer Maschinenbau GmbH**  
Eibergstrasse 2-8  
6330 Kufstein / Austria  
Phone +43 (5372) 6 48 93  
Fax +43 (5372) 6 14 76

chromojet@zimmer-austria.com  
[www.zimmer-austria.com](http://www.zimmer-austria.com)

**Zimmer**  
AUSTRIA